



Infrared Laser Series

## ORION

Pulsed Fiber Laser  
for Industrial Application



## Features

- High contrast marking in extended frequency range
- From 20W to 50W
- Excellent beam quality
- Profibus and embedded PC as option
- Air cooled
- Easy of integration (19 inches rack)

## Applications

- Marking and deep engraving
- High contrast on laser annealing
- Safety ID marking for high speed productivity on Polycarbonate and PVC

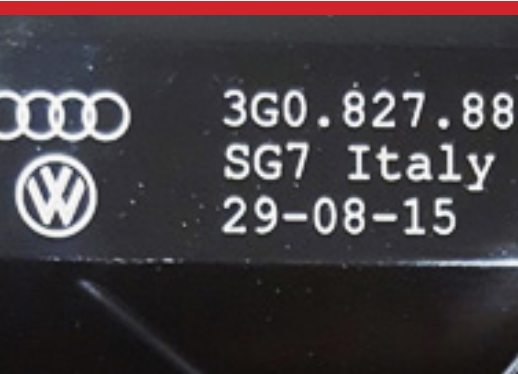

# Infrared Laser Series

# ORION

## ORION 20

## ORION 30

## ORION 50

Operational mode	Pulsed Fiber Laser			
Wavelength	[nm]	1064 +/- 2		
Nominal Power	[W]	20	30	50
Beam quality (nominal)	[M <sup>2</sup> ]	<1.5		
Polarization		Random		
Pulse repetition rate	[kHz]	20 - 100	30 - 100	50 - 200
Pulse energy	[mJ]	1		
Pulse width	[ns]	100 +/- 20		
Peak power (nominal)	[kW]	10		
Power Supply	[Vac; Hz]	90-240 ; 50/60		
Power consumption	[W]	<800	<1000	<1500
Cooling system		Air		
Communication (*)		RS232		
Compliance		2004/108/CE; 2006/95/CE; EN60950-1; EN 608225-1; EN 12626		

Note: Integrated embedded PC as option \*Ethernet or Profibus available upon request

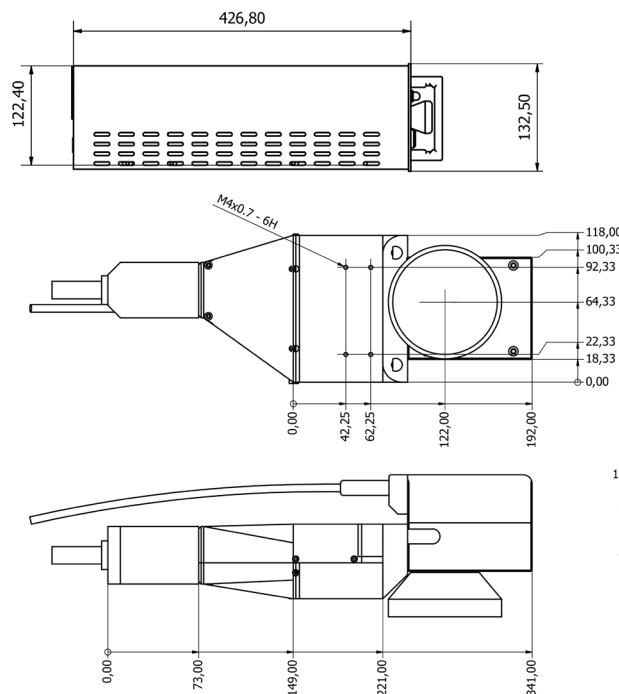
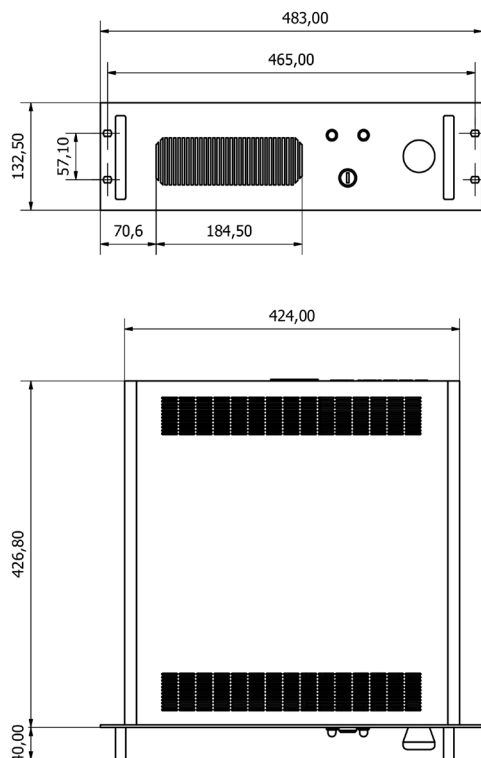

Specifications are subject to variations and updates without notice.  
Class 4 laser source.

This OEM laser component is for sale solely to qualified manufacturers, who shall provide interlocks, indicators and other appropriate safety features, in full compliance with 21 CFR 1040 and/or other applicable national and local regulations.



## Orion Layout



GAP Laser Systems s.r.l.  
A Certified and ISO 9001:2008 Company

**GAP LASERSYSTEMS**  
custom industrial solutions

Via IV Novembre 116 - 21058 Solbiate Olona (VA) - ITALY  
Tel: +39 0331 072637 - Fax: +39 0331 072695  
www.gaplaser.com - info@gaplaser.com