



Infrared Laser Series

ORION

Pulsed Fiber Laser
for Industrial Application



Features

- High contrast marking in extended frequency range
- From 20W to 50W
- Excellent beam quality
- Profibus and embedded PC as option
- Air cooled
- Easy of integration (19 inches rack)

Applications

- Marking and deep engraving
- High contrast on laser annealing
- Safety ID marking for high speed productivity on Polycarbonate and PVC

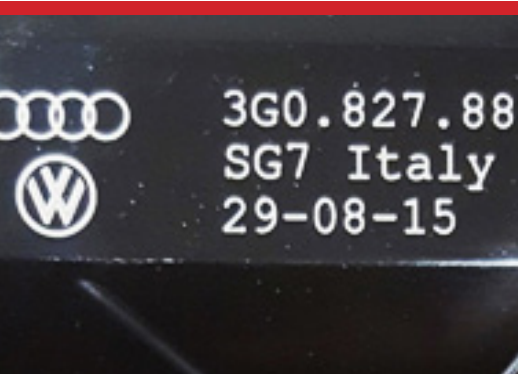

Infrared Laser Series

ORION

ORION 20

ORION 30

ORION 50

ORION 100

Operational mode		Pulsed Fiber Laser			
Wavelength (Typ.)	[nm]	1064			
Nominal Power	[W]	20	30	50	100
Beam quality (Max)	[M ²]	<2			
Polarization		Random			
Pulse repetition rate	[kHz]	2 - 500			
Max pulse energy	[mJ]	1			
Pulse width	[ns]	100 +/- 20			
Peak power (nominal)	[kW]	10			
Power Supply	[Vac; Hz]	90-240 ; 50/60			
Power consumption	[W]	<800	<1000	<1500	<1700
Cooling system		Air			
Communication		RS232 (Ethernet available upon request)			
Compliance		2004/108/CE; 2006/95/CE; EN60950-1; EN 608225-1; EN 12626			

- Integrated embedded PC as option
- 3D System available upon request

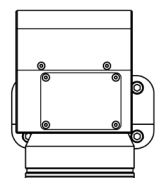
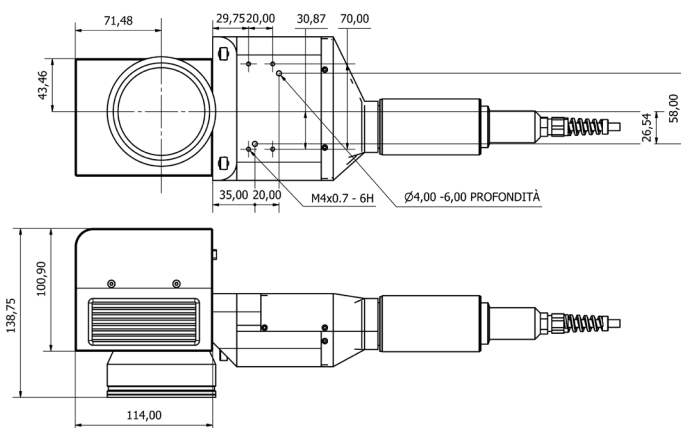
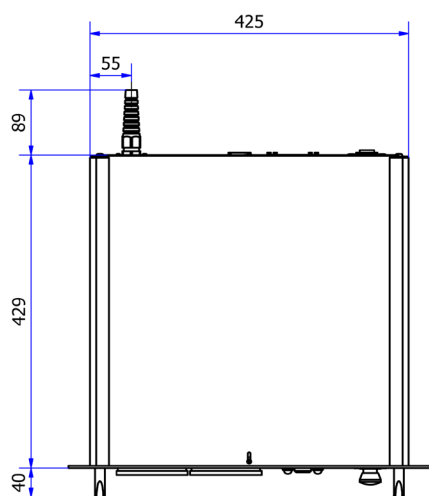
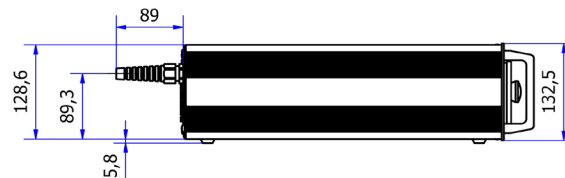
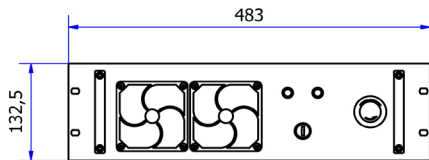

Orion Layout

Specifications are subject to variations and updates without notice. Class 4 laser source. This OEM laser component is for sale solely to qualified manufacturers, who shall provide interlocks, indicators and other appropriate safety features, in full compliance with 21 CFR 1040 and/or other applicable national and local regulations.



GAP LASERSYSTEMS
custom industrial solutions

GAP Laser Systems s.r.l.
A Certified and ISO 9001:2008 Company

Via IV Novembre 116 - 21058 Solbiate Olona (VA) - ITALY
Tel: +39 0331 072637 - Fax: +39 0331 072695
www.gaplaser.com - info@gaplaser.com